

BCJ-K

Explosion Proof Emergency Light



Features

- Zone 1&2, Zone 21&22
 - Built-in maintenance-free battery pack, the battery will be charged automatically when power is supply. And it will be in emergency light when the power fails.
 - The lamp head can be rotated around 270° from top to bottom, with wide lighting range.
 - Easy to install.
 - LED indicator of main, charge, fault to easy to know the status of the light.
 - Self inspections annual month. And test button for testing any time for user.
 - Equipped with an explosion-proof buzzer with a 65dB-85dB voice. When the product is in fault status, the buzzer will work 1-3s every minute to remind the user to maintain the product.
-

Compliance

ATEX Standard:

ATEX

CE

RoHS

Technical Parameter

Specification	
European (ATEX)	CE 1282 Ex II 2G Ex d IIC Gb
Gas and Dust	CE 1282 Ex II 2D Ex tb Db
IP Degree	IP66
Input voltage	220-240VAC, 50-60Hz
Power consumption (W)	2*3
Back-up Battery	>120mins
Entries	NPT3/4"
Size (mm)	243*250*78
Weight (kg)	2.6kg
Mounting Styles	Ceiling; Wall; Base Mount

Dimension

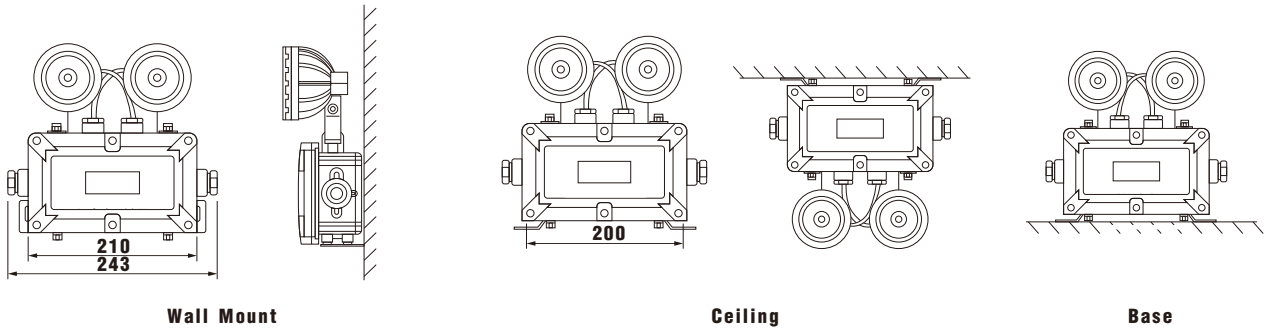

Measurement unit: mm

Model No.	Net Weight (Product)	Product Dimension
BCJ-K	2.6kg	243x250x78 mm